

FO - 7900 x 1045 x 200

Composants	N° rep.	Nb.	Long.	Larg.	Ep.
Planches	1	1	7900	975	25
Patins FO	2	18	1045	100	50
Madriers	3	2	7900	63	75
Madriers	4	2	7774	63	75
Longerons	5	2	849	63	75
Remplis	6	21	241	63	75

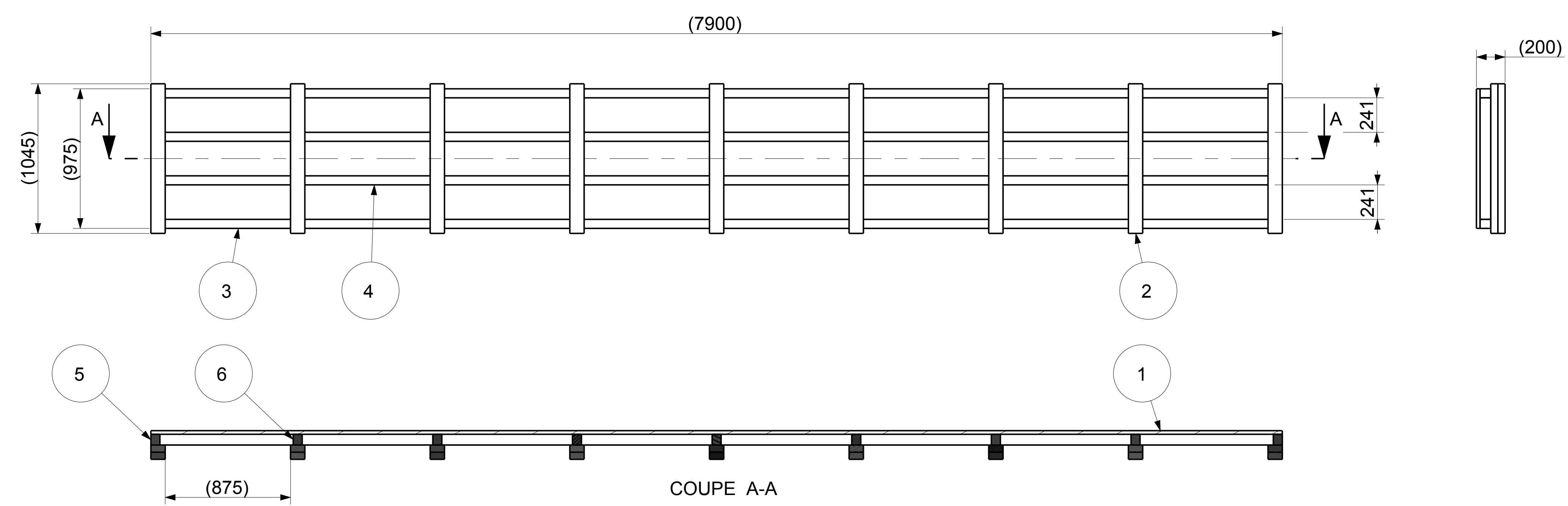

PC - 975 x 850 x 35

Composants	N° rep.	Nb.	Long.	Larg.	Ep.
Barres	1	2	975	100	25
Montants E.	2	2	650	100	25
Pan. OSB.	3	1	975	850	10

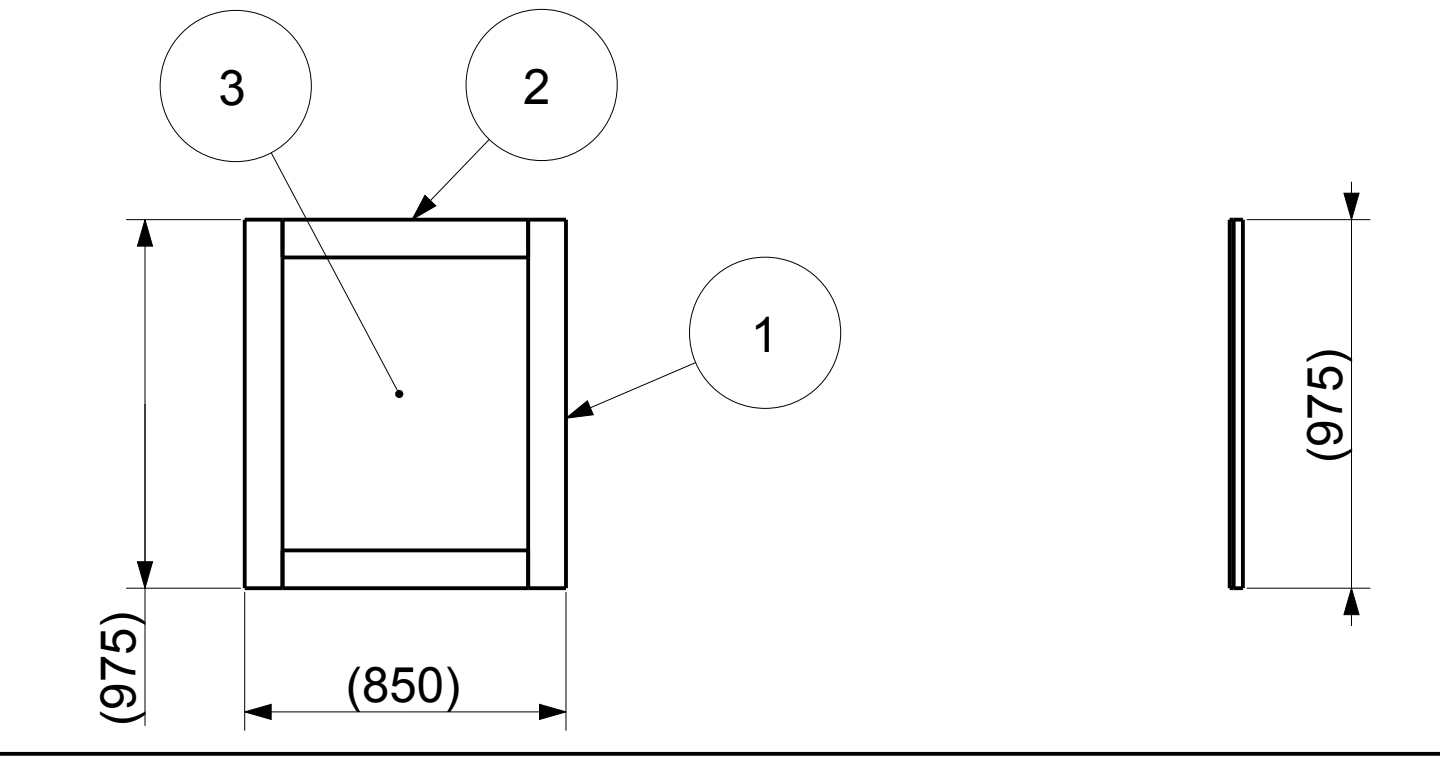

A - 2536 x 318 x 747

Composants	N° rep.	Nb.	Long.	Larg.	Ep.
Pan. OSB.	1	2	2506	747	15
Pan. OSB.	2	4	318	747	15

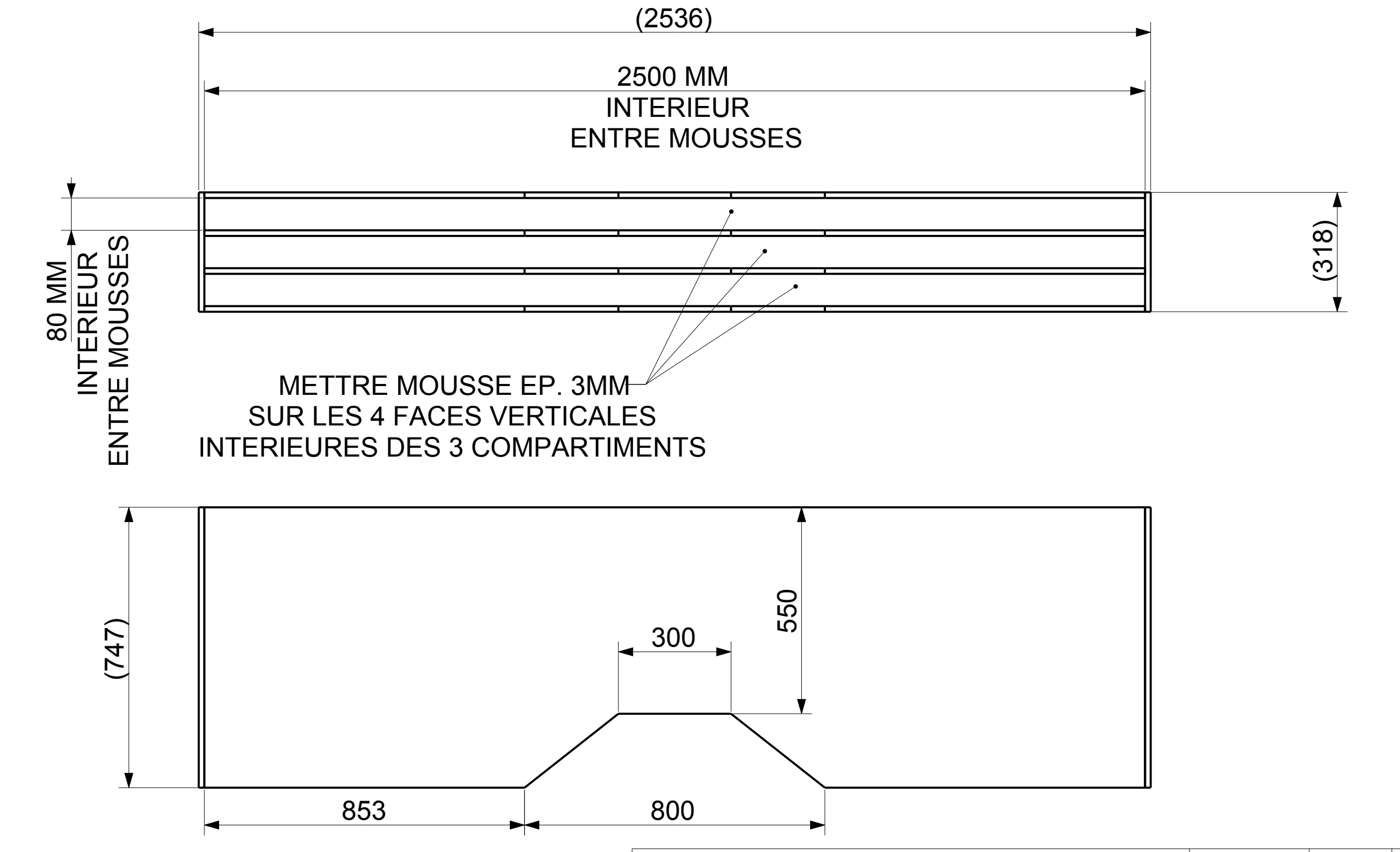

GC - 7970 x 850 x 35

Composants	N° rep.	Nb.	Long.	Larg.	Ep.
Barres	1	2	7970	100	25
Montants E.	2	9	650	100	25
Pan. OSB.	3	1	7970	850	10

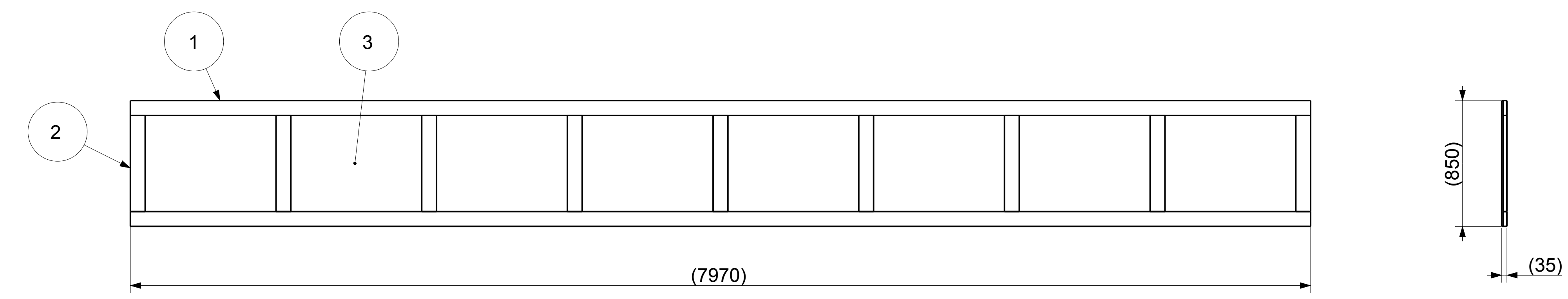

CO - 7970 x 1045 x 35

Composants	N° rep.	Nb.	Long.	Larg.	Ep.
Barres	1	2	7970	100	25
Montants E.	2	9	845	100	25
Pan. OSB.	3	1	7970	1045	10

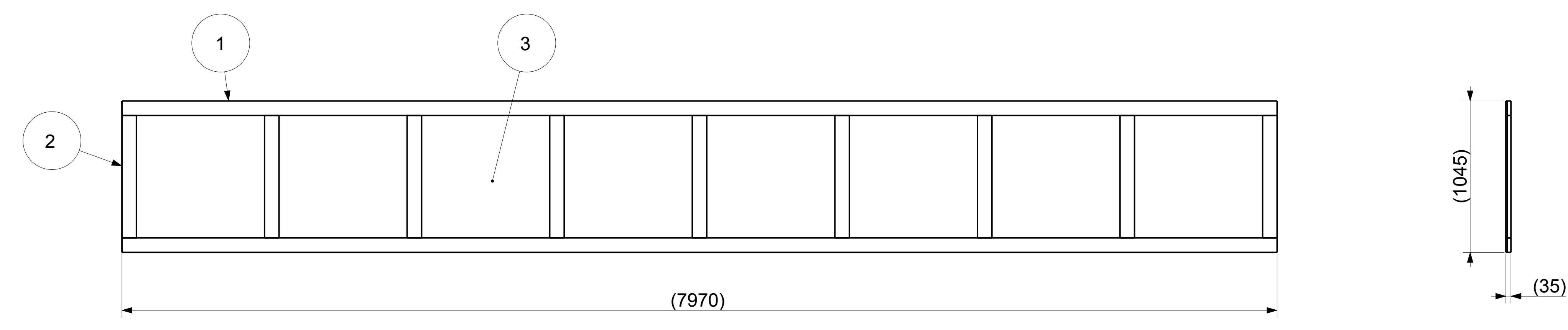

Modifications		Modif par	Date	Indice

Observation: Sauf spécification tolérances ISO 2768 m-K

Matière: Usinage: -

Traitement: - Poids: -

DESIGNATION

CAISSE DAHER

SARL
CONSTRUCTION
LORENNE

Dessiné: ACN Echelle: N° Plan: Format:

Vérifié: 0,05 D12600-000 A0

Date: 01/2017

Ce plan est la propriété de G2 méca-concept SARL et ne peut être récopié ou divulgué sans notre autorisation.

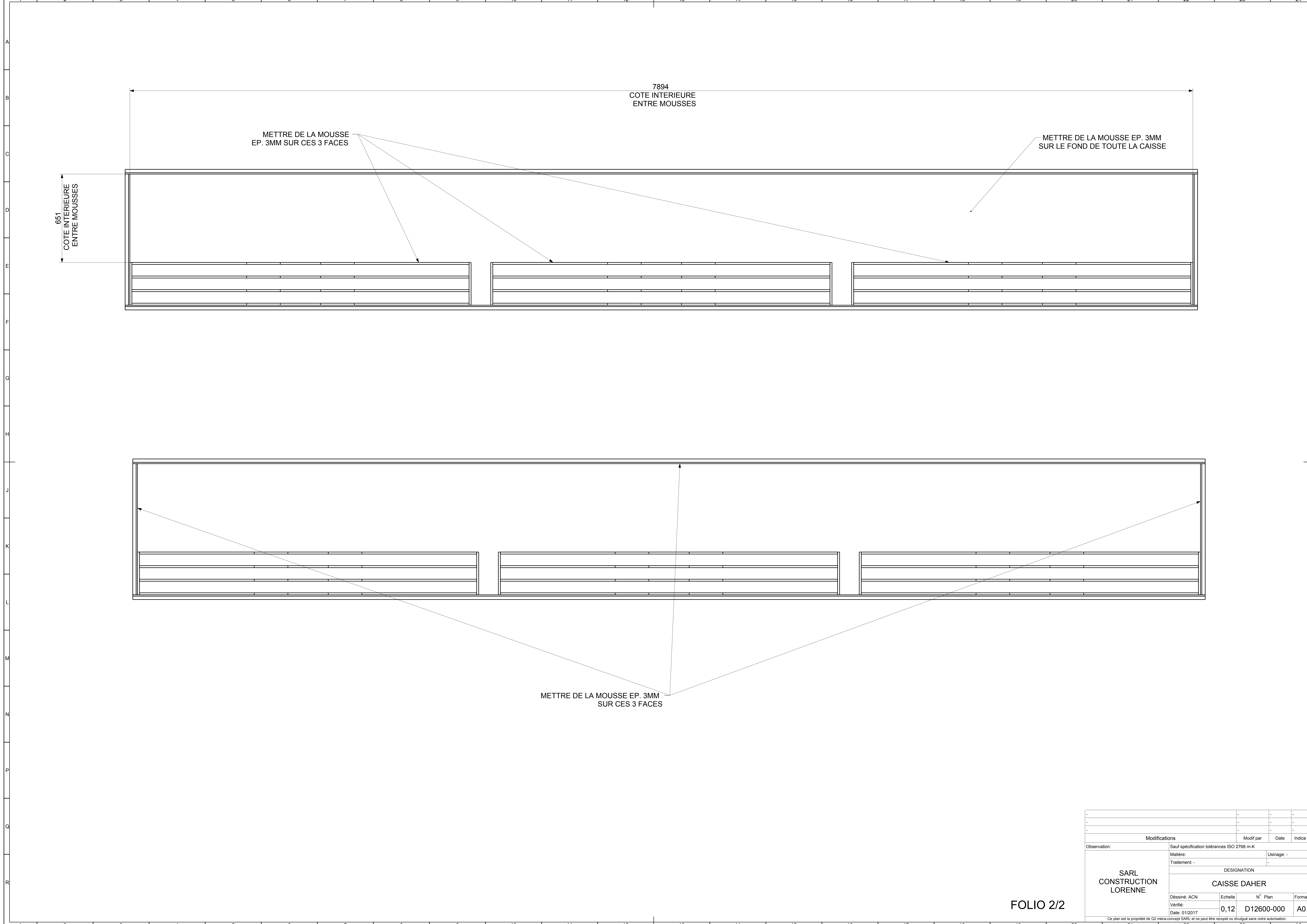

7894
COTE INTERIEURE
ENTRE MOUSSES

METTRE DE LA MOUSSE
EP. 3MM SUR CES 3 FACES

METTRE DE LA MOUSSE EP. 3MM
SUR LE FOND DE TOUTE LA CAISSE

651
COTE INTERIEURE
ENTRE MOUSSES

METTRE DE LA MOUSSE EP. 3MM
SUR CES 3 FACES

-	-	-	-
-	-	-	-
-	-	-	-
Modifications		Modif par	Date
Observation:		Sauf spécification tolérances ISO 2768 m-K	
Matière:		Usinage: -	
Traitement: -		-	
DESIGNATION			
CAISSE DAHER			
Dessiné: ACN	Echelle	N° Plan	Format
Vérifié:	0,12	D12600-000	A0
Date: 01/2017	Ce plan est la propriété de G2 méca-concept SARL et ne peut être récopié ou divulgué sans notre autorisation.		